

DISCREPANCIES OF BUILDING
REGULATIONS,
The Case of Capital City of Jakarta

Budi A.Sukada, IAI

ASIAN FORUM 4
Tokyo, 08-10 December 2004

BASIC ITEMS OF REGULATIONS

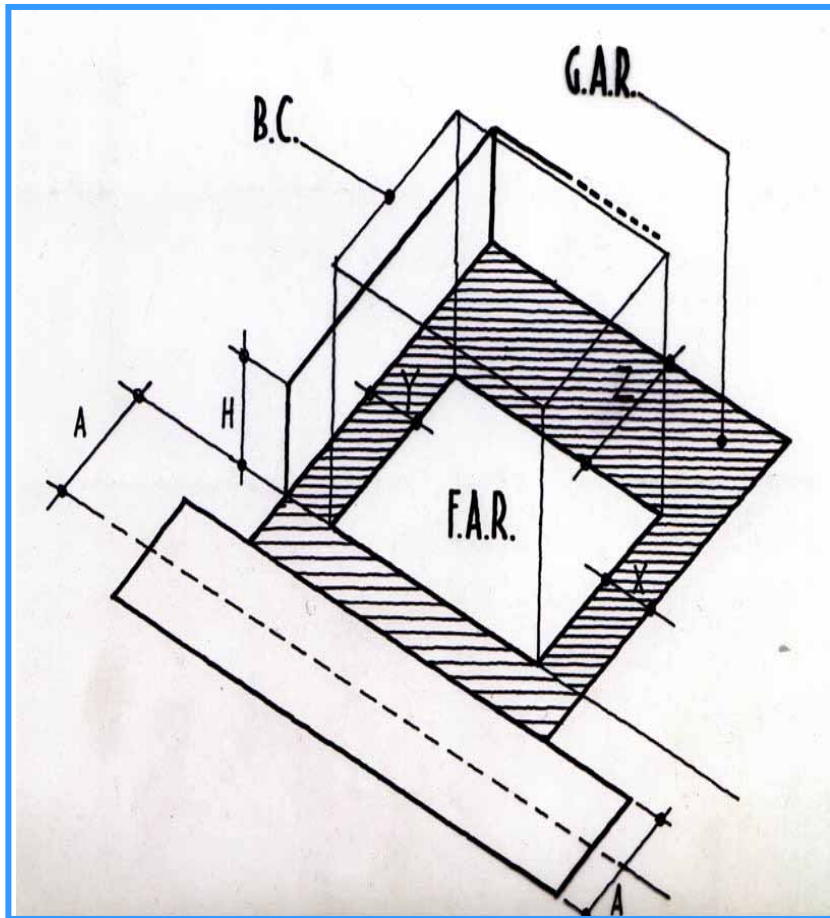

The basic items being regulated are:

- Size & Dimension of the Site
- Building Height
- Floor Area Ratio
- Building Coverage
- Green Coverage
- Right of Way

Intended Result: HIERARCHY ENVIRONMENT

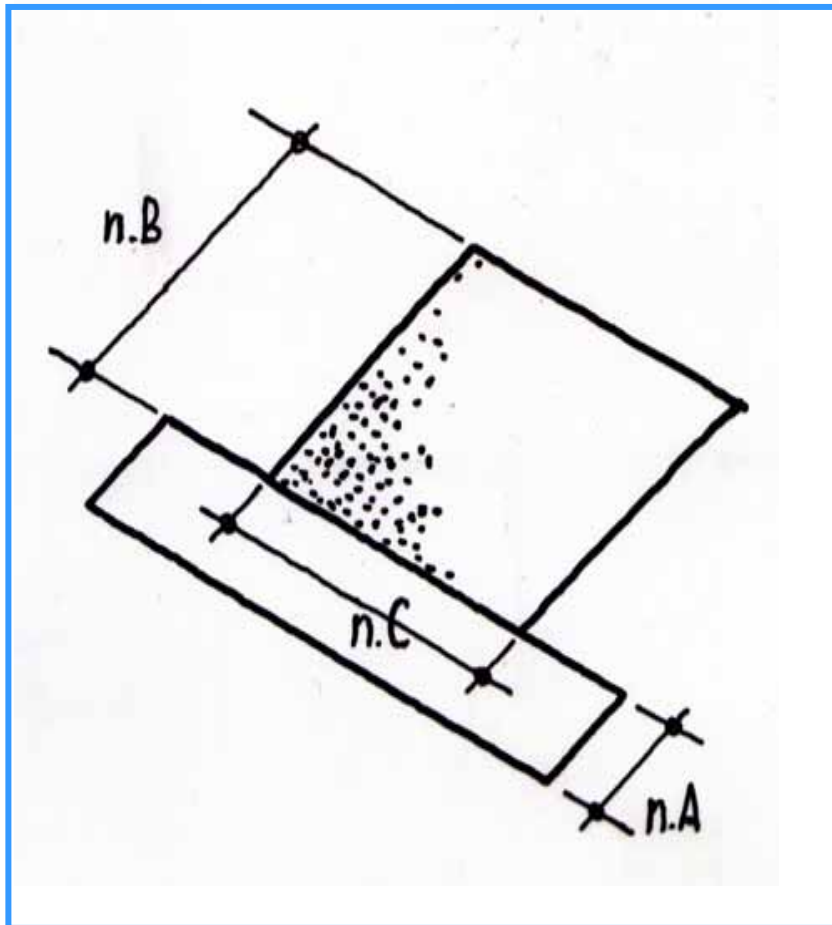

The regulations are supposed to create a hierarchy within the related built environment.

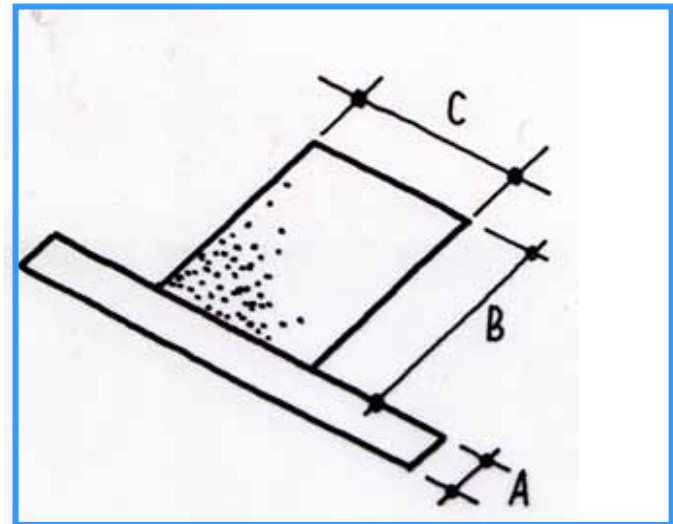

Intended Result: HEALTHY & SAFE BUILT ENVIRONMENT



Another intended result is to have a sufficient distance of buildings to one another so as to provide enough space for the air to circulate as well as to have an easy access for emergency.

Intended Result: SPACIOUSNESS



Other intended result is to have a sufficient distance of building line from the street so as to provide spaciousness within the built environment



Discrepancy Caused by New Ownership



Many small sites have been taken by new owners who made them into one large site. They then built a new structure, being served by the original narrow street.

Discrepancy Caused by Street Widening



Some streets have been made wider to cope with the increasing traffic by overtaking the pedestrian and infrastructure area.

Discrepancy Caused by Occupying Pedestrian Area



In many cases the pedestrian areas have even been taken care by the owners to become their belonging.

Discrepancy Caused by Additional Storey of Building



Many owners built additional structure in the location that is supposed to be a free distance area between buildings.

Discrepancy Caused by New Storey of Building



Many owners even built new storey of building over the original one.



Discrepancy Caused by Violation of Distance Between Buildings



Many owners their building over the distance between buildings.



Discrepancy Caused by Violation of Building Coverage



Many owners their building over the distance between buildings.



Discrepancy Caused by Violation of Zoning

Many buildings have altered into other functions, followed by alteration of pedestrian and infrastructure area.



Intervention of Private Zone



Privacy of many original buildings have been invaded by new structure, especially in the backyard.



CONCLUSION

- Any building must obey regulations within the related area of built environment.
- Any regulation must be made with the ability to cope future situation.